

FlexGuard® 5853 Wireless Glassbreak Detector Installation Instructions

Refer to Supplemental Information (next page) for complete descriptions of these installation steps

5853 Glassbreak Detector Internal Parts

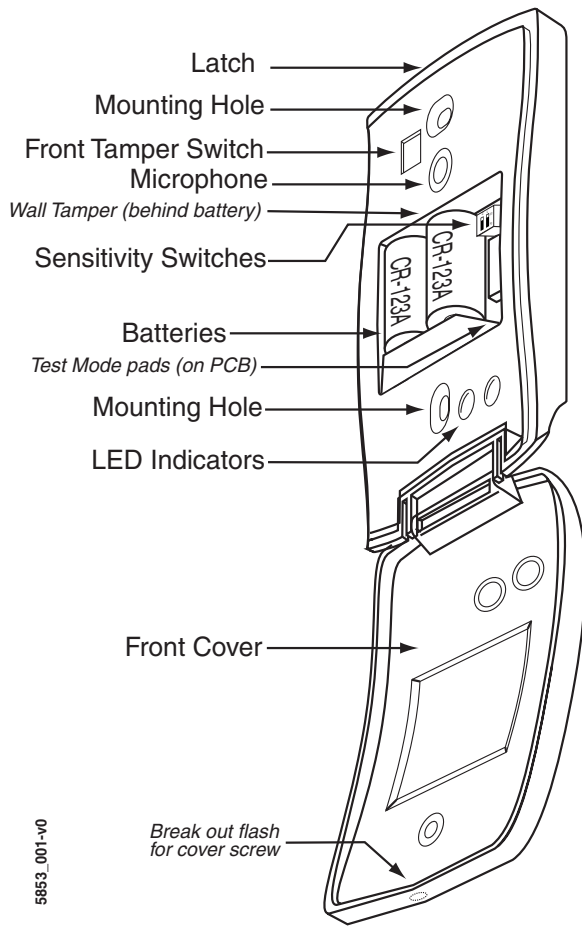

Connect Batteries

Remove pull tab to connect batteries

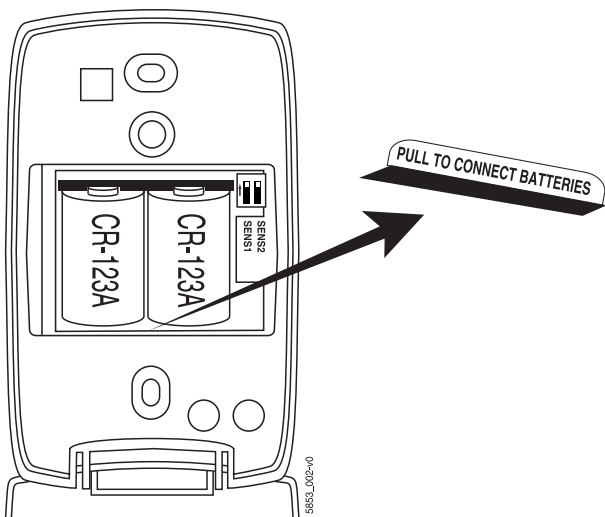

Select Mounting Location

For the best detector performance, select a mounting location that is:

- within 7.6 m (25 feet) of the protected glass;
- within clear view of the protected glass;
- at least 2 m (6.5 feet) from the floor;
- at least 1 m (3.3 feet) from forced air ducts;
- at least 1 m (3.3 feet) from sirens or bells greater than 5 cm (2 inches) in diameter.
- between the protected glass and any heavy window coverings that may be present.

Alternatively, when heavy window coverings are present, the detector can be mounted on the frame of the window.

Avoid mounting the detector on the same wall as the protected glass, on free-standing posts or pillars, or in rooms with noisy equipment (air compressors, bells, power tools, etc.), if this equipment is operated when the detector is armed.

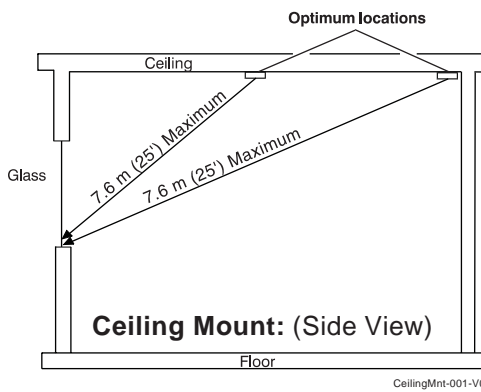
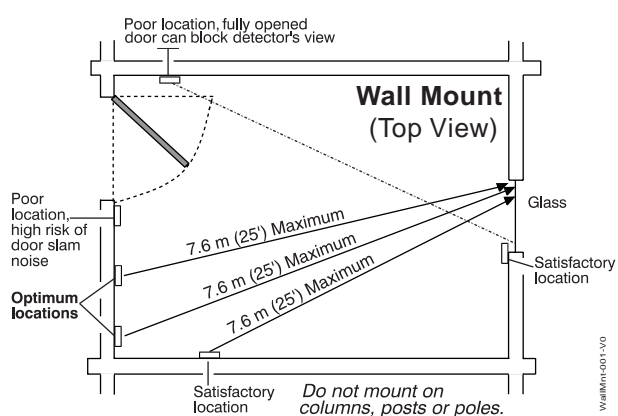

NOTE: If the device is ceiling mounted, the end with the hole (Microphone end) should face the protected glass.

Set Sensitivity (Range)

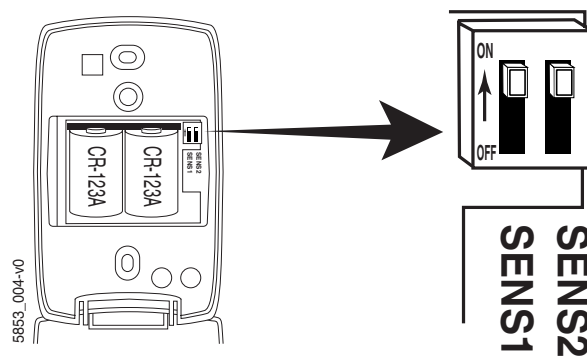

SENS1 & SENS2 configure sensitivity

SENSITIVITY	APPROXIMATE RANGE	SENS1	SENS2
MAX	7.6m (25 ft)	OFF	OFF
MEDIUM	4.6m (15 ft)	ON	OFF
LOW	3m (10 ft)	OFF	ON
LOWEST	1.5m (5 ft)	ON	ON

NOTE: Ranges are approximate and vary with each room's acoustic properties. Always verify range with a FlexGuard FG-701 Glassbreak Simulator.

Enroll Detector

Refer to text and control panel's installation instructions.

When programming the transmitter, specify:

- Input Type = 3 (Supervised RF)
- Loop Number = 1

Mount Detector

- Use mounting holes as a template to mark mounting locations on ceiling or wall.
- **If using the optional back tamper**, remove the batteries, then mark the wall tamper location through its mounting hole.
- Mount detector using appropriate hardware.
 - NOTE:** A screw capture feature designed to make ceiling mounting easier will cause some resistance when inserting the screw into the plastic.
- Close detector cover when finished.

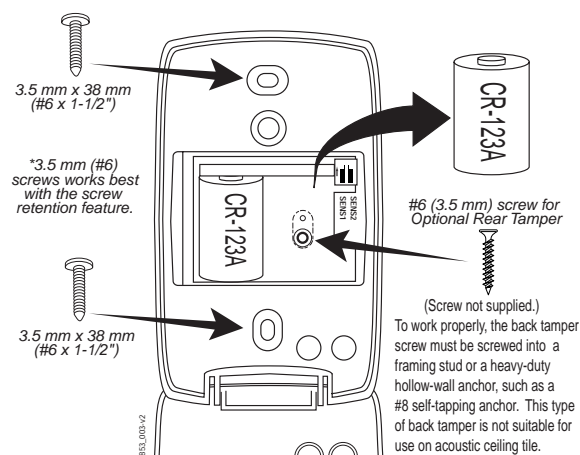

*The screw retention feature simplifies installation: A rib in the screw cavity lightly holds the screw in place when installing the detector.

Test Detector Installation

Enter Test Mode using a FlexGuard FG-701 Glassbreak Simulator (see Testing the Detector on the next page). To enter Test Mode manually, short the Test Mode pads (as shown below).

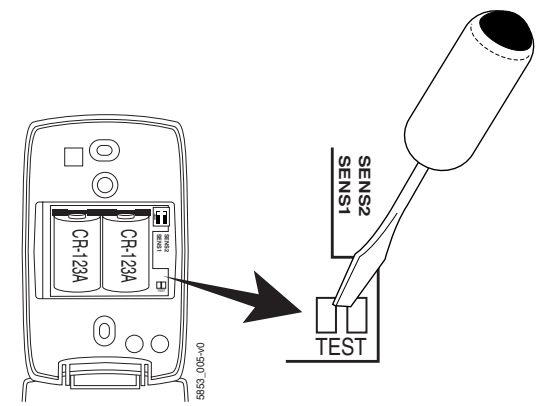

Install Cover Screw (optional)

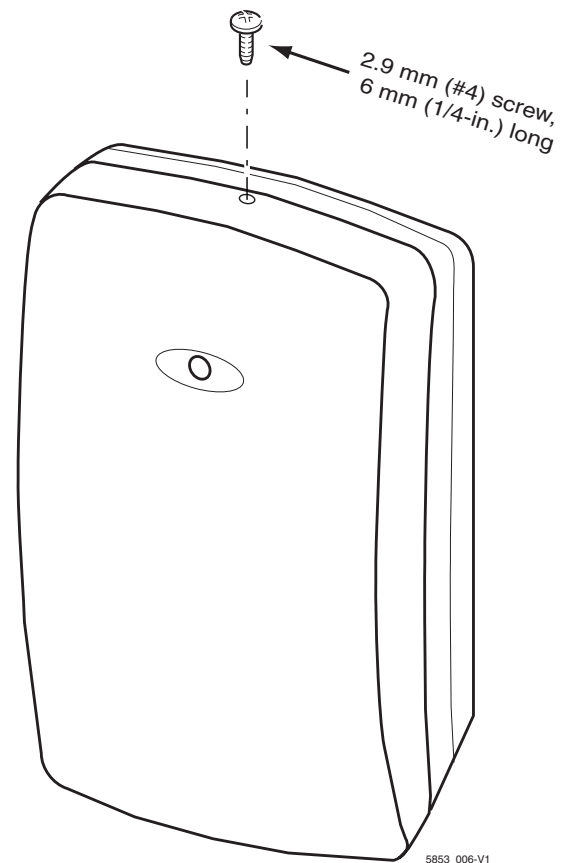

FlexGuard® 5853 Wireless Glassbreak Detector Supplemental Information

Refer to Installation Instructions and diagrams (next page) when installing this product

1. General Information

The 5853 Wireless Glassbreak detector with Transmitter senses the sound of breaking plate, tempered, laminated, wired, coated and sealed insulating glass. The self-contained detector includes a transmitter that can send alarms, tamper signals, and low battery messages to the control panel. The sensor is compatible with 5800-series wireless hardware*, and is designed for continuous operation using two 3V lithium batteries (CR-123A or equivalent; included).

Prior to installation, you must:

- Connect its batteries by removing the tab,
- Adjust the detector's sensitivity, and
- "Enroll" the detector's serial number.

Refer to the following sections to install the 5853.

This detector is both UL and ULC listed.

*Compatible control units for use in Canada require the use of listed RF receivers that have been subjected to compatibility analyses by Underwriters' Laboratories of Canada. Refer to the Installation Instructions for the control unit before installing burglar alarm components.

2. Connecting Batteries/Initial Power Up

To connect the batteries, remove the tab from the end of the battery holder. The detector will start its power up sequence, in which both the LED indicators will illuminate for one second. (The LED indicators are described later in these instructions.)

3. Adjusting Detector Sensitivity (Range)

The 5853 has four sensitivity settings, which are set using the SENS1 and SENS2 DIP switches. The settings are: 1) maximum; 2) medium; 3) low; and 4) lowest. By default, sensitivity is set to MAXIMUM.

To change the detector's sensitivity, use a small screwdriver to adjust the SENS1 and SENS2 switches, as shown in the table below:

SENSITIVITY	APPROX. RANGE	SENS1	SENS2
MAX	7.6m (25 ft)	OFF	OFF
MEDIUM	4.6m (15 ft)	ON	OFF
LOW	3m (10 ft)	OFF	ON
LOWEST	1.5m (5 ft)	ON	ON

4. Enrolling Detector Into 5800-Series Receiver

Before the control panel will recognize the 5853, you must program the device's serial number into the control panel. This process, ("enrolling") is described in detail in the control panel's installation instructions.

When programming the transmitter, specify:

- Input Type = 3 (Supervised RF)
- Loop Number = 1

You can transmit the device's serial number automatically or enter it manually. To transmit the number automatically, momentarily activate the front tamper switch. To enter the serial number manually, refer to the control panel's instructions to enroll the serial ID number which appears on the product.

5. Selecting Installation Location

The 5853 can be mounted on the ceiling or the wall. Choose a mounting location that is at least 2.1m (7 feet) from floor and no more than 7.6m (25 feet) from the farthest protected glass. Be sure the detector has an unobstructed line-of-sight to the protected glass!

Before mounting the detector permanently, test it to ensure that it functions satisfactorily in the chosen mounting location. Verify that the detector can detect glassbreak sounds, following the directions in the "Testing the Detector" section. Ensure that the 5853 is within range of the receiver, following the instructions for the signal-strength test found in the control panel's installation instructions. (To send the signal required by the test, activate the detector's front tamper switch.) If the detector fails, relocate it and repeat both tests.

6. Mounting the Detector

NOTE: If using wall tamper and installing on dry wall (sheet rock), position the detector so that the wall tamper is over a wall stud or ceiling joist, or use a drywall anchor so the tamper screw will not pull out.

NOTE: If the device is ceiling mounted, the end with the hole (Microphone end) should face the protected glass.

To mount the detector:

1. Using the 5853 mounting holes as a template, mark mounting locations on the ceiling or wall.
2. **If using the optional wall tamper**, remove the batteries, then mark the wall tamper location through its mounting hole. The tamper screw must be securely mounted. See details on page 1.
3. If required by the mounting location, install wall anchors for the mounting screws.
4. Secure the 5853 to the wall or ceiling, oriented so the microphone has the best line-of-sight to the protected glass.
5. Reinstall the batteries if previously removed.
6. Close and secure the detector front cover.

7. Testing the Detector

The detector should be tested at least once each year. Test the detector with the FlexGuard FG-701 Glassbreak Simulator. Other simulators will not give accurate indication of range.

To enter the Test Mode with the FG-701:

1. Stand within 4.6 m (15 feet) of the detector.
2. Switch the FG-701 to ACTIVATE and MANuAl modes.
3. Point the front [speaker] of the glassbreak simulator towards the detector and press the red START button. The simulator buzzes a short activation code.

When the detector enters Test Mode, the green LED on the detector flashes about once per second. If the green LED does not flash, move closer to the detector and repeat the procedure.

To enter Test Mode manually:

1. Open the front cover.
2. Use a screwdriver to short the Test Mode pads on the PC board (see diagram on next page).
3. Close the front cover.

The detector's green LED blinks approximately once per second to indicate that it has entered the test mode.

Testing the Detector (flex and audio signals):

To test the 5853, do the following:

1. Place the detector in Test Mode.
2. Set the FG-701 switches to the TEST and FLEX positions.
3. Position the FG-701 near the farthest point of the protected glass, and point the speaker directly at the detector. If window coverings are present, close them fully and hold the FG-701 between the coverings and the protected glass.
4. Press the red START button. The simulator clicks on and starts an eight-second armed period.
5. Generate a flex signal by carefully striking the glass with a cushioned tool. The FG-701 responds with a burst of glassbreak audio.

If the detector receives both the flex and audio signals properly, its red Alarm LED lights for 5 seconds. (Red Alarm LED does not latch.)

Testing the Detector (audio signals only):

The FG-701 can also be used to test the detector's ability to receive audio signals only. See the FG-701 Operating Instructions for additional information. When it receives the audio signal, the detector flickers its green Event LED.

Exiting Test Mode:

When you have finished testing, exit Test Mode by following the same procedure used to enter Test Mode. The detector automatically exits Test Mode five minutes after the last event is detected.

8. LED Indicators

The detector is equipped with two LEDs: a green Event LED and a red Alarm LED. When the LEDs are enabled during testing, they light in a variety of patterns to convey the detector's operational status. The following table summarizes the LED messages. (Please note that the LEDs are only enabled during Test Mode, and are inactive during normal operation.)

CONDITION	GREEN LED	RED LED
Power up	ON 1 second	ON 1 second
Test Mode	Flash once per sec	OFF
Test Mode, event detected	Flicker	OFF
Test Mode, alarm	Flash once per sec	ON 5 seconds
Low Battery *	Flash once per sec	Flash once per sec

* If battery voltage drops too low, LEDs are no longer visible.

9. Cover Screw

The front cover can be secured after installation. To do so, remove the cover breakout flash (illustration on next page) and secure the front cover with a 6 mm (¼-in.), 2.9 mm (#4) screw (supplied).

10. Maintaining Proper Operation

To maintain the 5853 Glassbreak Detector in proper working order, please observe the following:

Replace the batteries when the system indicates a low battery condition (refer to the control panel's operating instructions.) Be sure to replace the batteries with the proper type and voltage, and ALWAYS replace both batteries at the same time.

The installer should inform the end user that fans, air conditioners, blowers, loudspeakers, or other sources of vibration and sound should not be introduced into the protected area after installation of glassbreak detectors. If unavoidable, the end user must contact the alarm service company to re-adjust/re-test the equipment as needed. Additionally, this device should not be relocated without the advice or assistance of the alarm service company.

11. Protected Glass Types Chart

NOTE: The 5853 is NOT recommended for protection of glass areas smaller than 27.6 cm x 27.6 cm (10-7/8 inches x 10-7/8 inches).

Glass Type*	Nominal Thickness	
	Minimum	Maximum
Plate	2mm (3/32 in.)	10mm (3/8 in.)
Tempered	3mm (1/8 in.)	10mm (3/8 in.)
Laminated ^{1,3}	3mm (1/8 in.)	14mm (9/16 in.)
Wired	6mm (1/4 in.)	6mm (1/4 in.)
Coated ^{2,3}	3mm (1/8 in.)	6mm (1/4 in.)
Sealed Insulating ^{1,3}	3mm (1/8 in.) [13mm (1/2 in.) overall]	6mm (1/4 in.) [19mm (3/4 in.) overall]

* Minimum size for all types is 28cm (11 in.) square; glass must be framed in the wall or mounted in a barrier at least 0.9m (36 in.) wide.

¹ Protected only if both plates in the unit are broken

² Coated glass with security films up to 0.35mm (14 mils) thick (including films for solar protection) may be used. Evaluated with the these products: 3M® SCOTCHSHIELD® SH14CLARL – 0.35mm (14 mils), 4 ply film; Film Technologies International, Inc.'s GLASS-GARD GGLL 1200 has been evaluated with this product by Underwriters Laboratories, Inc.

³ In compliance with Underwriters Laboratories of Canada's Standard for Intrusion Detection Units (CAN/ULC-S306-M89):

- a. Plate glass 3mm (1/8-in.) to 10mm (3/8-in.) can be used.
- b. ULC recognizes a maximum range for protecting sealed insulating glass, 1/8" laminated and coated glass of 3.8m (12.5 ft.); sensitivity should be set to Max.

12. Specifications

Power: Two 3 V Batteries (included). Replace only with ADEMCO #466, Panasonic CR123A, Sanyo CR123A, Duracell DL123A, or Varta CR123A (Lithium Manganese Dioxide)

Ranges: Maximum range is 7.6m (25 ft) from farthest protected glass. No minimum range.

Operating Temperature: -10° to 50° C (14° to 122° F)
For indoor use environment

Dimensions: 12.5cm (4.95") x 7.8cm (3.09") x 2.8cm (1.1")

Weight: 146g (5.12 oz.)

Accessories: FlexGuard FG-701 Glassbreak Simulator

Compliance: FCC and IC Verified, UL Listed, ULC Listed, C-Tick

13. NOTICES

FCC NOTICE This device complies with Part 15 of the FCC rules and RSS 210 of Industry Canada. Operation is subject to the following two conditions: (1) This device may not cause harmful interference, and (2) this device must accept any interference received, including interference that may cause undesired operation. Unauthorized changes or modifications could void the user's authority to operate the equipment.

TO THE INSTALLER

Regular maintenance and inspection (at least annually) by the installer and frequent testing by the user are vital to continuous satisfactory operation of any alarm system. The installer should assume the responsibility of developing and offering a regular maintenance program to the user as well as acquainting the user with the proper operation and limitations of the alarm system and its component parts. Recommendations must be included for a specific program of testing (at least weekly) to ensure the system's proper operation at all times.

REFER TO THE INSTALLATION INSTRUCTIONS FOR THE RECEIVER/ CONTROL WITH WHICH THIS DEVICE IS USED FOR DETAILS REGARDING WARRANTY INFORMATION AND LIMITATIONS OF THE ENTIRE ALARM SYSTEM.