

ALARM.COM DOORBELL CAMERA INSTALLATION GUIDE

INTRODUCTION

Your customers will always know who is at the front door with an Alarm.com Doorbell Camera. Now with two options to choose from – our original Wi-Fi Doorbell Camera and our new Slim Line – it's easy to deliver front door awareness to even more customers!

Each Alarm.com Doorbell Camera features a doorbell with an integrated camera, PIR motion sensor, digital microphone and speaker, enabling homeowners to answer the door and speak to visitors via two-way audio – all right from their app.

Customers can also record doorbell triggered clips, set motion triggered automation rules and receive real-time alerts. Visit alarm.com/doorbell for more information.



Wi-Fi Doorbell Camera



Slim Line

INCLUDED MATERIALS

- Wall mounting bracket
- Wall screws
- Masonry anchors

DEVICE COMPATIBILITY WITH ALARM.COM

Alarm.com Doorbell Cameras

The following Doorbell Cameras are fully compatible with Alarm.com:

- Alarm.com Slim Line Doorbell Camera
- Alarm.com Wi-Fi Doorbell Camera, SkyBell-HD Edition

Slim Line Incompatible with SkyBell and Other Platforms

The Slim Line Doorbell Camera is not compatible with

other platforms and apps, such as the SkyBell platform.

SkyBell HD Cameras

Certain SkyBell HD cameras, not purchased through Alarm.com, may not be compatible with the Alarm.com platform.

SkyBell V1 and V2 Not Compatible

SkyBell V1 and V2 cameras are not compatible with Alarm.com.

REQUIREMENTS

Power and Chime Type

8-30VAC, 10VA or 12VDC, 0.5 to 1.0A wired to an in-home mechanical or digital doorbell chime. **Note:** A Digital Doorbell Adapter must be installed if a digital doorbell chime is present. See below for more information.

WARNING: An in-line resistor (10 Ohm, 10 Watt) is required when installing the doorbell camera without a

wired, in-home doorbell chime. This is typically done when testing the doorbell or performing a demonstration. Failure to install a resistor when a chime is not present may result in damage to the doorbell camera.

Wi-Fi

Upload speed of 2 Mbps is required. Compatible with Wi-Fi 802.11 b/g/n, 2.4 GHz up to 150 Mbps.

Mounting

The mounting plate affixes to a flat surface (a power drill may be required) and uses the existing doorbell wiring.

PRE-INSTALLATION CHECKLIST

Working Doorbell Check

A wired doorbell circuit is required to provide power to the doorbell camera. First check that the existing wired doorbell is working and that it is wired properly.

There is a power issue if the existing doorbell does not ring the indoor chime when the button is pressed. This issue must be addressed before beginning the doorbell camera installation process.

Wired Doorbell Check

Check that the existing doorbell is wired by visually inspecting the doorbell button for wires. If necessary, the doorbell can be removed from the wall to check for wiring. You can also inspect the chime inside the home – a chime plugged into a power outlet might indicate an incompatible wireless doorbell system is in place.

Doorbell Chime Type Check

Locate the chime inside the home and remove the faceplate. Identify the chime as one of the following types:

Mechanical Chime – If the chime has metal bars and a striker pin, it is mechanical and will work without additional hardware.

Digital Chime - If the chime has a speaker that plays a tone when pressed, it is digital and will **require the installation of the Digital Doorbell Adapter and the enabling of the digital doorbell setting in the app to function properly.**

Tube Chime - If the chime has a series of tubular bells, it is a tube chime and is incompatible with the doorbell camera.

Mobile App

Download the latest Alarm.com Mobile App for iOS or Android (version 4.4.1 or higher for video streaming).

Intercom System – If the doorbell button fixture includes a speaker, it is an intercom system and is incompatible with the doorbell camera.

No Chime – If there is no chime in the system, the customer will only receive alerts on their phone and a resistor (10 Ohm 10 Watt) must be used in-line with the doorbell camera.

Digital Doorbell Adapter

The Digital Doorbell Adapter is available for purchase through the Alarm.com Dealer Website.

Wi-Fi Password Check

Make sure you have the password for the Wi-Fi network in the home where you plan to install the doorbell camera. Verify the Wi-Fi credentials before you begin by connecting a smartphone or laptop to the Wi-Fi network and attempting to access a website.

Internet & Wi-Fi Speed Check

A Wi-Fi Internet upload speed of at **least 2 Mbps is required** at the location where the doorbell camera is installed.

Follow these steps to check the connection speed:

1. Go to the location where the doorbell camera will be installed
2. Close the door
3. Disable the cellular (LTE) Internet connection on your device and connect to the home's 2.4 GHz Wi-Fi network
4. Run a speed test (for example, SpeedOf.me or speedtest.net) to determine the Internet speed
5. In the test results, note the **Upload** speed. The Alarm.com Wi-Fi Doorbell Cameras require an upload speed of at least 2 Mbps.

HARDWARE INSTALLATION

Use Alarm.com Doorbell Camera Hardware

Alarm.com's Doorbell Camera hardware must be used:

- Alarm.com Wi-Fi Doorbell Camera
- Alarm.com Slim Line Doorbell Camera

SkyBell HD consumer hardware is not supported. Slim Line Doorbell Camera hardware is not supported on the SkyBell platform or other service provider platforms.

Remove Existing Doorbell Button

Take care to prevent the existing doorbell wires from slipping into the wall.

Attach the Doorbell Mounting Bracket to the Wall

Feed the existing doorbell wires through the hole in the center of the bracket. Affix the bracket firmly to the wall by driving the provided wall screws through the top and bottom holes in the bracket. Failure to make the bracket flush on the wall could cause a poor power connection between the bracket and the doorbell camera.

Connect Power Wires to the Mounting Bracket

Loosen the terminal screws and insert the wires beneath the screws. Do not short (touch together) the wires during this process. Tighten the screws. The wires must be of approximately equal thickness, and the screws should be tightened approximately the same amount so that the screwheads are flush.

If the wires are thick, splice short lengths of additional thinner wire. The splice joints can be hidden inside the wall, and the thinner wire can be used to connect to the mounting bracket.

Attach the Doorbell Camera to the Mounting Bracket

Slide the top of the doorbell camera down on to the mounting bracket and push the front of the doorbell camera toward the wall. Tighten the set screw located on the bottom of the camera, being careful not to damage it (power tools should not be used with the set screw). The camera's LED should begin to illuminate.

Connecting the Digital Doorbell Adapter

If the home has a mechanical chime, you may skip this section. If the home has a digital chime, a Digital Doorbell Adapter is required.

Remove the cover from the digital chime and locate the wire terminals. Completely remove the screws from the terminals and temporarily move the wires out of the way.

Connect the Digital Doorbell Adapter wires to the chime:

- J1 -> "Front" Terminal (on Digital Doorbell)
- J3 -> "Trans" Terminal (on Digital Doorbell)

Connect the J2 wire to a wire from the wall, and connect the J4 wire to a wire from the wall.

Reassemble and reinstall the digital chime in its original location.

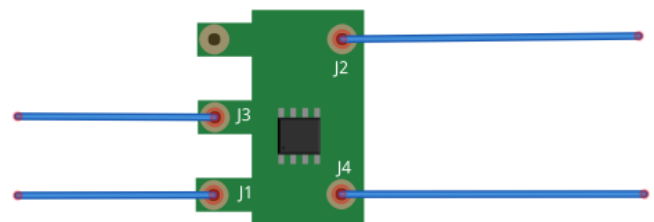

SYNCING WITH ALARM.COM

Ready to Sync

The Doorbell Camera is ready to sync when the LED is alternating Red and Green. This LED pattern indicates that the camera is in Wi-Fi Access Point (AP) mode. In this mode, the camera broadcasts a temporary Wi-Fi

network. During the syncing process, you will connect to this network when instructed by the app. The app will configure the Doorbell Camera.

If the LED is not alternating Red and Green, see the troubleshooting section below.

Log In to the Alarm.com App

Use the login and password for the account that will have the Doorbell Camera.

Select Add a New Doorbell Camera

Navigate to the Doorbell Camera page by selecting the Doorbell Camera tab in the left navigation bar. If a Doorbell Camera is already installed on the account, you can add a new camera by selecting the Settings icon on the existing Doorbell Camera's screen.

Note: If you do not see the Doorbell Camera tab, the Doorbell Cameras service plan add-on needs to be added to the account. You may also need to check the customer's login permissions to ensure they have permission to add a Doorbell Camera.

Follow the On-Screen Instructions

Keep your mobile device on the home's Wi-Fi network (or on LTE) and follow the on-screen instructions. You will be prompted to provide a name for the camera.

When Instructed, Connect to the Doorbell Camera's Temporary Wi-Fi Network

The syncing process will instruct you to connect to the Doorbell Camera's temporary Wi-Fi network. The

network is named Skybell_123456789 (or SkybellHD_123456789), where 123456789 corresponds to the device's serial number. On iPhone or iPad, you must leave the Alarm.com app, enter the Settings app, select Wi-Fi and select the SkyBell network. On Android, this process is completed within the app.

Enter the Home's Wi-Fi Password

Very carefully enter the home's Wi-Fi password. If you must configure static IP addresses or the customer has a hidden Wi-Fi network, use the Manual Configuration tab.

Enable Push Notifications & Recording Schedules

The mobile device that is syncing the doorbell camera is automatically added as a notification recipient.

Enable the Digital Doorbell in the App

If you installed a Digital Doorbell Adapter, the device must be enabled from the Alarm.com app.

Open the Alarm.com app and select the Doorbell Camera tab. Select the Settings icon for the camera and turn on the option to enable the Digital Door Chime. Select Save.

NOTIFICATIONS & RECORDING SCHEDULES

Notifications

Notifications are alerts that are sent immediately to the customer's mobile phone when activity is detected by the Alarm.com Wi-Fi Doorbell Camera. Push notifications help the customer take full advantage of their new Doorbell Camera.

Acknowledging a Doorbell Camera push notification will route the user directly to the call screen and enter a two-way audio call.

Button Pushed – Receive a notification when the doorbell button is pushed. By acknowledging the notification, you will automatically join a two-way audio call and receive a live video feed from the camera.

Motion – Receive a notification when the doorbell detects motion. By acknowledging the notification, you will automatically join a two-way audio call and receive a live video feed from the camera.

Importance of Push Notifications

Enabling push notifications and adding the necessary recipients are critical to the success of a Doorbell Camera installation. Push notifications allow the customer to instantly see, hear and speak to visitors at the door.

We recommend the customer select the "Keep me logged in" option on the Login screen in the Alarm.com app so that the customer will be able to respond to push notifications from the Doorbell Camera more quickly.

Recording Schedules

Recording schedules control the times and events during which the Doorbell Camera records clips.

Call (Button Pushed) – Record a clip when the doorbell button is pushed.

Motion – Record a clip when the doorbell detects

motion. Reduce the number of motion-triggered clips by selecting the "Low" motion sensitivity setting. Navigate to the Customer Website Video Device Settings page and adjust the "Sensitivity to Motion" slider to the "Low" position.

Event Triggered (for example, Alarm) – Record a clip after a sensor is activated or after an alarm.

Notes:

Recording duration is typically around one minute. Clips are longer during an alarm or when a mobile user joins a call after a button or motion event.

Recording schedules do not need to match notification settings. You can enable recording schedules for both button and motion events but only enable notifications for button events if desired.

Accounts have a maximum number of clips that can be uploaded in a month and saved on the account.

Doorbell camera clips count toward that limit.

LED COLORS, BUTTON FUNCTIONS AND GENERAL TROUBLESHOOTING

Battery Charging

If the LED is alternating between **Red and Blue** (HD Edition) or pulsing **Blue** (Slim Line), the doorbell camera's battery is charging. The duration of the pre-syncing charge process varies due to differences in existing doorbell circuits but normally takes less than 30 minutes. See the *Power Information and Troubleshooting* section if this state persists.

Wi-Fi Connectivity

If the LED is **flashing Orange**, the doorbell needs to be manually placed into AP mode. Press and hold the Main Button until the LED begins rapidly flashing green, then release. The LED will flash green as the Doorbell Camera scans the Wi-Fi networks in the area. The Doorbell Camera should enter AP Mode after a couple of minutes and the LED should begin alternating Red and Green.

Enter AP Mode (Broadcast Syncing Mode)

Press and HOLD the Main Button until the LED begins a GREEN rapid strobe flash, then release the button.

When the LED flashes Green, it means the Alarm.com Wi-Fi Doorbell Camera is in the process of entering AP Mode.

The LED will alternate Red and Green when the device has entered AP Mode.

Power Cycle

Press and HOLD the Main Button until the LED begins a Blue rapid strobe flash. The power cycle could take up to 2 minutes.

Note: You can power cycle the Alarm.com Wi-Fi Doorbell Camera when it is in AP Mode (see instructions above). Press and HOLD the button until the LED flashes Blue.

Factory Reset

Caution: If you initiate a Factory Reset, the Doorbell Camera will need to be re-connected to Wi-Fi and re-synced with the account.

Press and HOLD the button until the LED begins a Yellow rapid strobe flash. The reset could take up to 2 minutes.

Notes:

The Alarm.com Wi-Fi Doorbell Camera will flash Blue before it flashes Yellow – do not release during the flashing Blue phase (this will power cycle the device).

You can factory reset the device when it is in AP Mode (see instructions above). Press and HOLD the Main Button until the LED flashes Yellow.

If a factory reset is performed on a camera that is already connected to Wi-Fi, the camera will need to be re-installed to re-establish its Wi-Fi connection.

Online Resources

Visit alarm.com/doorbell for troubleshooting tips, installation videos and more.

POWER INFORMATION & TROUBLESHOOTING

Wired Power Supply

The Alarm.com Wi-Fi Doorbell Camera requires a wired power supply.

Standard Doorbell Power

Standard doorbell power is 16VAC (Volts Alternating Current) provided by a transformer that steps Mains (120VAC) power down to low voltage. A common transformer is 16VAC 10VA (Volt Amps) – this is standard if the home has a single chime. If there are multiple chimes, the transformer will normally have a higher power (Volt Amps) rating. Other doorbell transformers offer variable Voltage outputs from 8VAC to 24VAC.

Battery for Uninterrupted Supply

The Doorbell Camera has a battery supply to provide power when the indoor doorbell chime is rung. To make the existing doorbell chime ring, the Doorbell Camera must short the doorbell circuit, diverting power from the camera. During this time, the battery is used to power the Doorbell Camera. The camera cannot run solely on battery power – a wired power supply is required. The built-in lithium battery has an expected battery life of 3 to 5 years, depending on usage.

Battery Charging

When the LED is alternating **Red and Blue** (HD Edition) or pulsing **Blue** (Slim Line), the battery is charging. The battery may need to charge prior to first-time use. The duration of the pre-syncing charge process varies due to differences in existing doorbell circuits but normally takes less than 30 minutes.

Power Supply Issues

The protection circuitry in doorbell transformers degrades over time and with use. This causes the power output of the doorbell transformer to drop. Eventually the power provided by the transformer drops below the power required by the Alarm.com Wi-Fi Doorbell Camera. At this point, the transformer needs to be replaced.

If installation is attempted and the doorbell transformer's power output does not meet the required power, the doorbell camera's LED will flash with a **Red** (HD Edition) or **Blue** (Slim Line) rapid double-flash pattern. If this pattern persists, the doorbell transformer must be replaced to provide sufficient power for doorbell camera operation.

Transformer Replacement

If you have confirmed there is a transformer failure, there are two options for transformer replacement. You can either use a plug-in wall-wart style transformer or wire a new transformer into the home's Mains lines, physically replacing the existing transformer (a professional electrician is recommended for this installation).

If you choose the first option, you can use an AC-AC Wall-Adapter transformer like those commonly used to power security panels.

Next, identify a power outlet near the existing transformer. Remove the low-voltage wires from the existing transformer and connect those wires to the new transformer. Plug the new transformer in to the power outlet and secure it in place.

POWER CONFIGURATIONS

No Chime – With Doorbell Camera – Resistor Required*

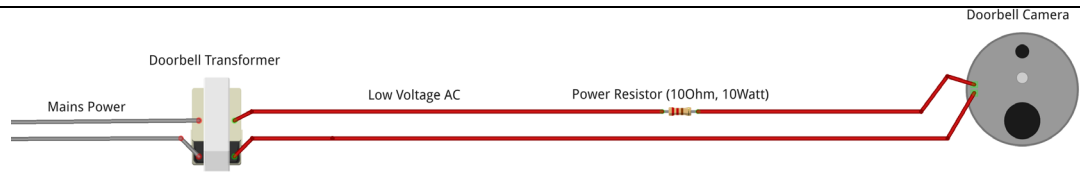

***WARNING:** This setup is designed for testing and demonstration purposes only. Failure to install a resistor (10 Ohm, 10 Watt) when a chime is not present may result in damage to the doorbell camera.

Mechanical Chime – Before Installation

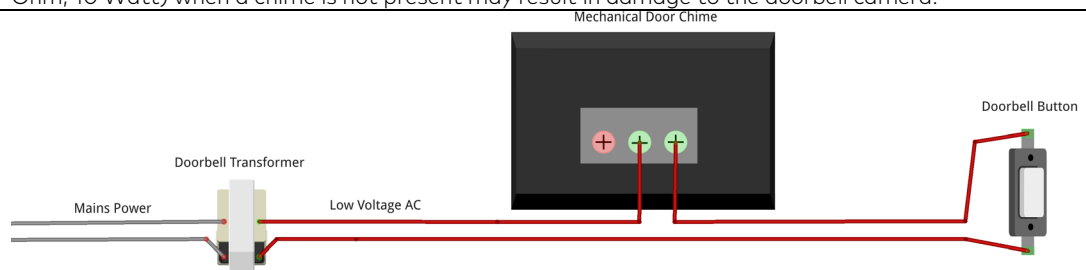

Mechanical Chime – With Doorbell Camera

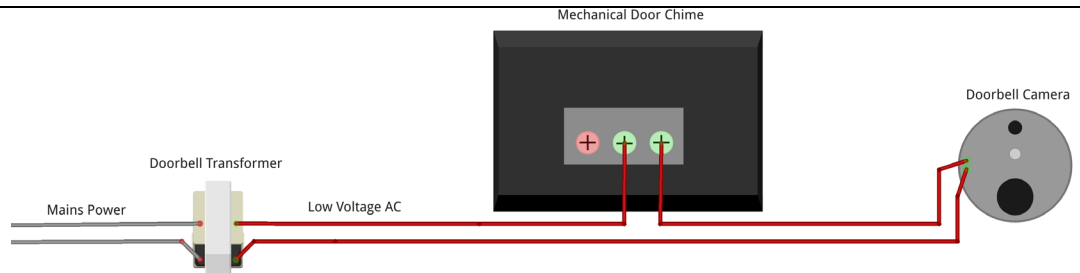

Digital Chime – Before Installation

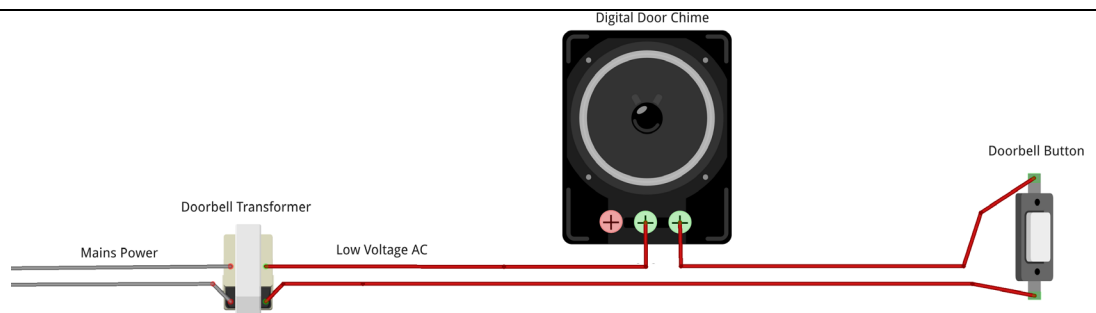

Digital Chime – With Doorbell Camera

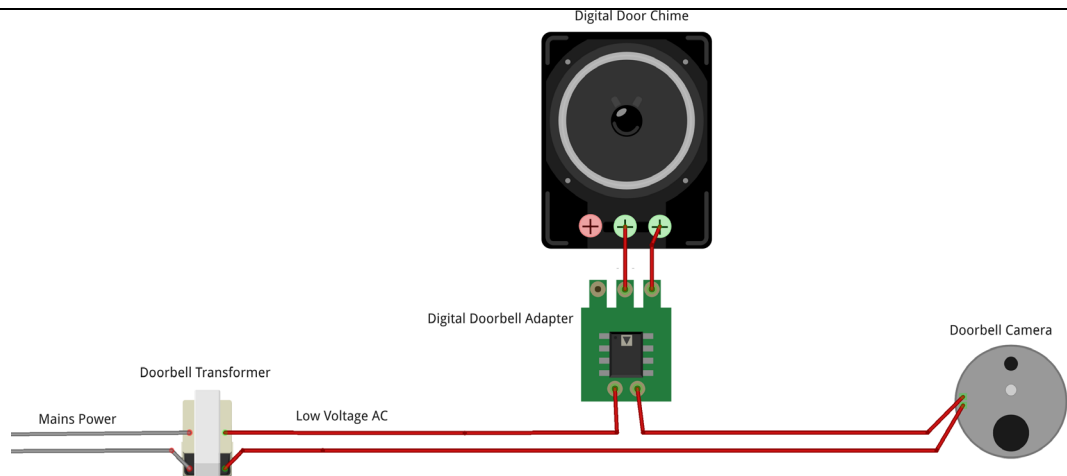

Wi-Fi Doorbell Camera

LED and Troubleshooting Reference Guide

LED Pattern Key



Normal Operation

Green | Solid



Ready and working normally

Use the Alarm.com app or Customer Website to choose a custom color in place of default green.

White | Solid



In Call mode

A call has been initiated or is occurring.

Yellow | Solid



Starting up

Please wait while the doorbell is booting up.

Red | **Blue** | Alternating flash



Battery is charging

Battery may charge for ~30 minutes after installation.

Blue | **Green** | Alternating flash



Connected to Wi-Fi,
waiting for server connection

Please wait.

Blue | **Yellow** | Alternating flash



Firmware update in progress

Please wait.

Requires Attention

Orange | Rapid double flash



No Wi-Fi connectivity

Check your Internet connection. Your Wi-Fi credentials may have changed. Enter Wi-Fi Access Point Mode (see Troubleshooting below) and re-add the doorbell camera using the app.

Red | Rapid double flash



Power supply issue

Contact your installer. The doorbell transformer may need to be replaced.

Troubleshooting

Press and hold doorbell button for the time shown to perform a troubleshooting step.

Green | Flashing



Entering Troubleshooting modes

Continue to press & hold for troubleshooting steps below.

Red | **Green** | Alternating flash



Wi-Fi Access Point mode

*Connect to the camera's temporary network and use the app to re-add the camera.
Push & hold ~60 sec until flashing, then release.*

Blue | Flashing



Power cycle

*Reboots the camera.
Push & hold ~70 sec until flashing, then release.*

Yellow | Flashing



Factory reset

*Factory resets the camera. Deletes all Wi-Fi and configuration information.
Push & hold ~80 sec until flashing, then release.*

Slim Line Doorbell Camera

LED and Troubleshooting Reference Guide



LED Pattern Key



Normal Operation



Ready and working normally

Use the Alarm.com app or Customer Website to choose a custom color in place of default green.



In Call mode

A call has been initiated or is occurring.



Starting up

Please wait while the doorbell is booting up.



Battery is charging

Battery may charge for ~30 minutes after installation.



Connected to Wi-Fi, waiting for server connection

Please wait.



Firmware update in progress

Please wait.

Requires Attention



No Wi-Fi connectivity

Check your Internet connection. Your Wi-Fi credentials may have changed. Enter Wi-Fi Access Point Mode (see Troubleshooting below) and re-add the doorbell camera using the app.



Power supply issue

Contact your installer. The doorbell transformer may need to be replaced.

Troubleshooting

Press and hold doorbell button for the time shown to perform a troubleshooting step.



Entering Troubleshooting modes

Continue to press & hold for troubleshooting steps below.



Wi-Fi Access Point mode

*Connect to the camera's temporary network and use the app to re-add the camera. **Push & hold ~60 sec until flashing, then release.***



Power cycle

*Reboots the camera. **Push & hold ~70 sec until flashing, then release.***



Factory reset

*Factory resets the camera. Deletes all Wi-Fi and configuration information. **Push & hold ~80 sec until flashing, then release.***